

  
  

#### NOTES TO PARENTS

Adult assistance will be required to set up the Race Track for very young drivers.  
Read right through these instructions before starting to assemble the race track

#### SAFETY NOTES

- This product is not suitable for children under 3 years because of small parts which can present a choking hazard. Some components have functional sharp edges – handle with care.
- The transformer is not a toy. It is a "Transformer for toys". Check that it is the correct voltage for your mains electricity supply. The transformer should be examined regularly for damage to the casing, plug pins and cables. In the event of such damage, do not use, but replace with an identical unit.
- The output terminals of the transformer must not be connected directly, or indirectly, to the output of any other AC circuit derived from a transformer or mains power supply.
- Before cleaning any part, disconnect the transformer from the mains electricity supply. Do not use liquid for cleaning.
- When new, hand controllers may emit an acrid smell and become warm in use. These effects are normal and will disappear after use but may return if the trigger is held in one position for a long time while racing.
- Please retain these details for future reference.

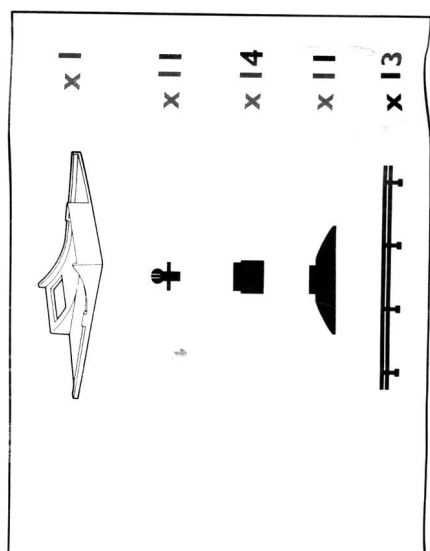
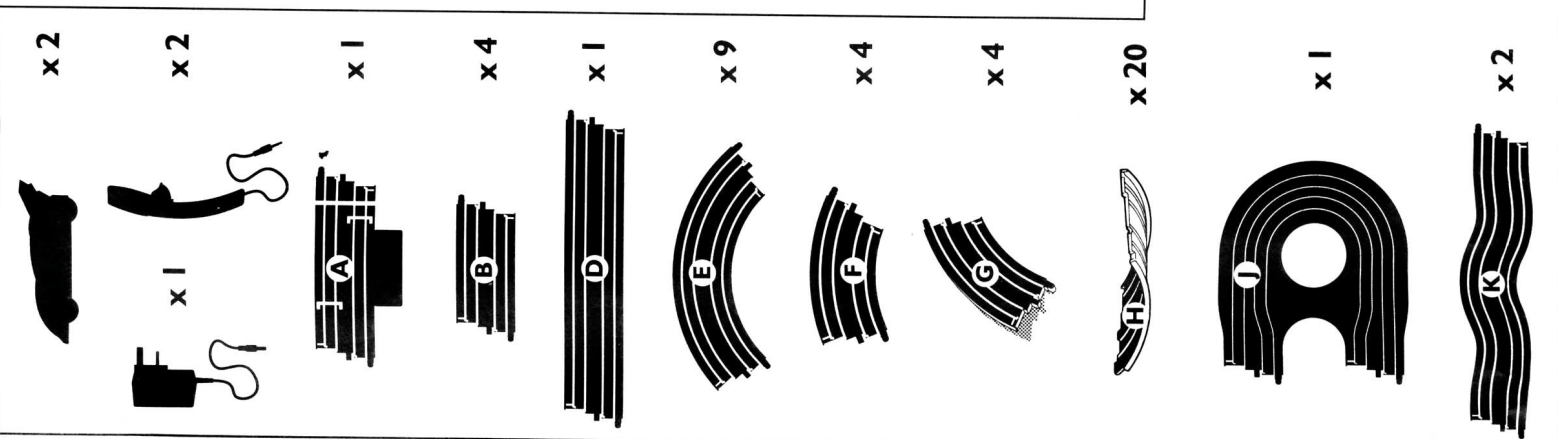
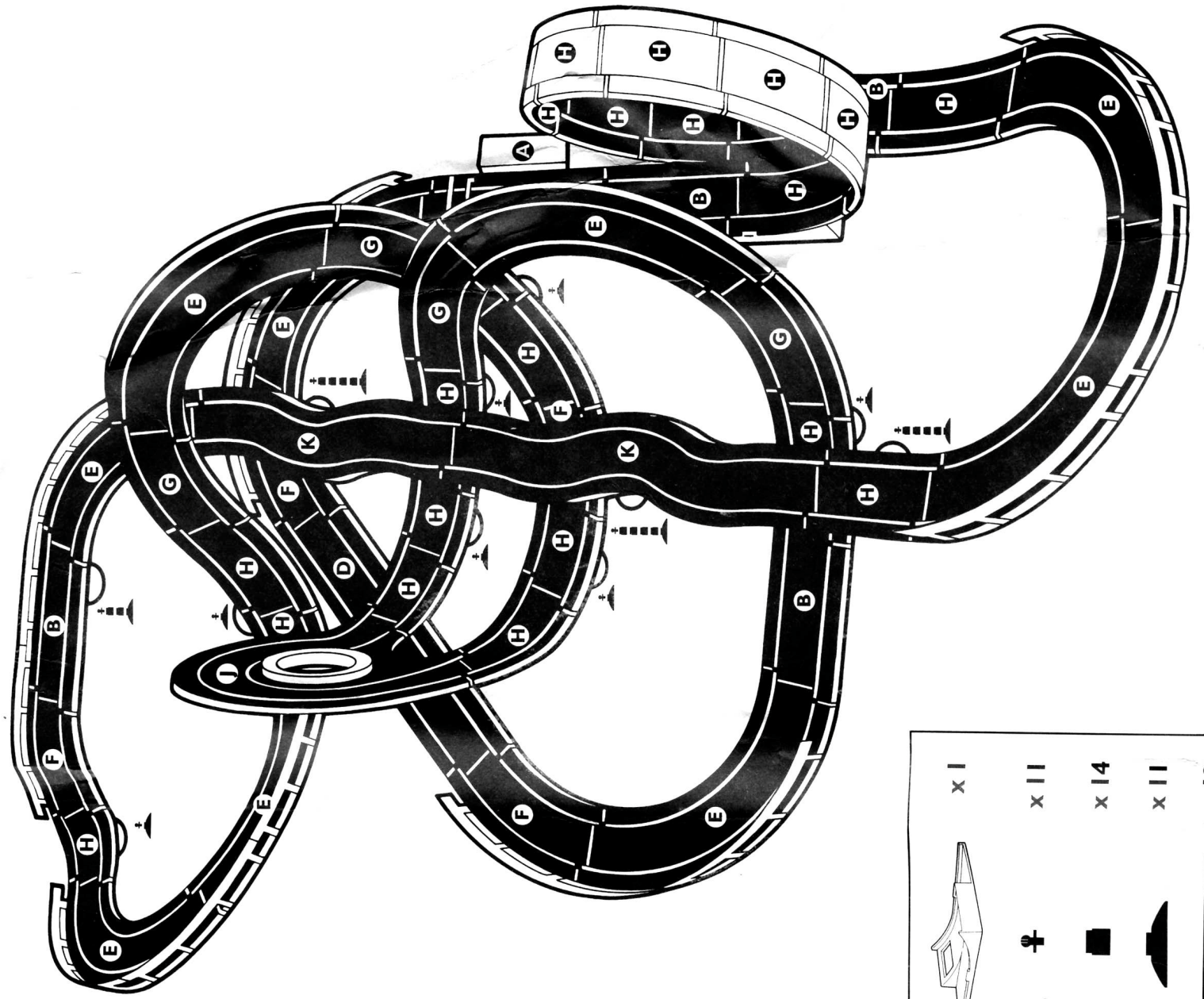

**TIP** Assemble loop section first. Locate Track B to Fixing B on Loop/Curve Base.  
**Note** There are always eight Curve Track Sections (H) in a Loop.

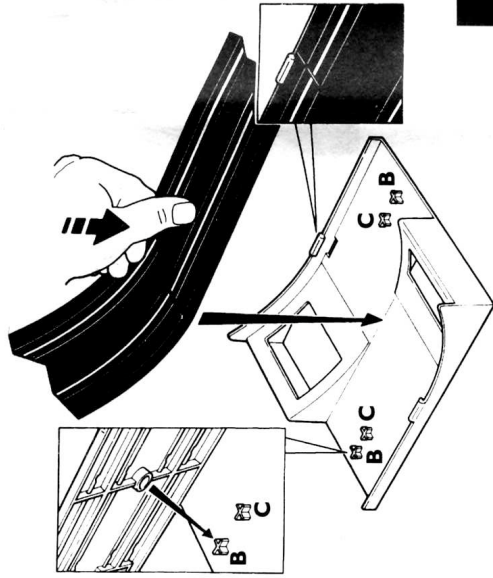

**1** Make up the race track by carefully identifying the different track sections in the track diagram from the illustrated contents list. Push the track sections firmly together in a straight line.

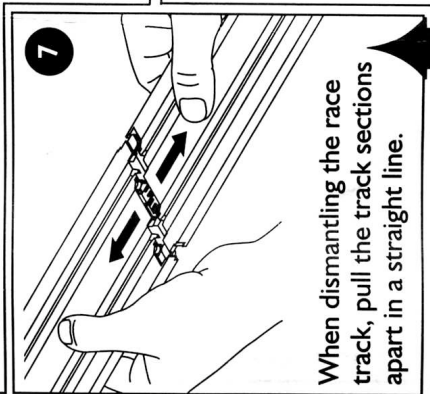

**2** When dismantling the race track, pull the track sections apart in a straight line.

**3** Make sure the sections are fully clipped together.

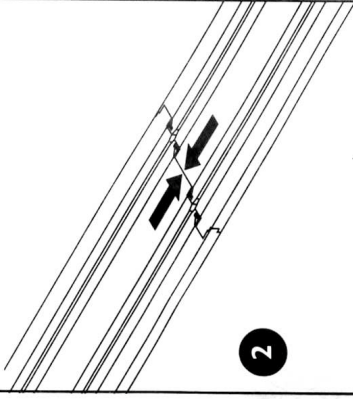

**4** Fit the track supports to make a bridge in the race track. The supports can be made to the height required by varying the number of sections.

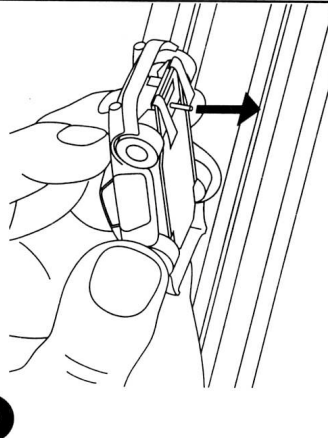
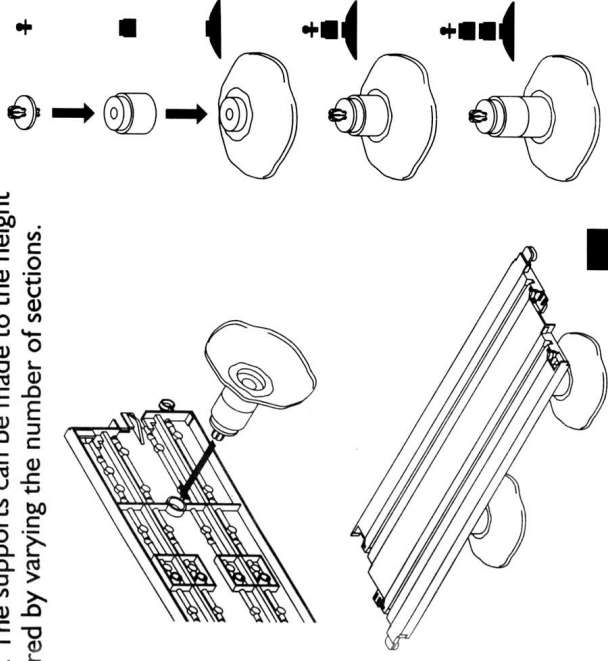

**5** Place a car on one side of the track with its guide pin in the slot between the metal rails. Slowly squeeze the trigger of its hand controller to make the car go around the track. Now put the other car on the other lane and use the other controller to test it. If both cars work on both lanes of the track, you are ready to race. Remember – the more you squeeze the trigger, the faster the cars will go, so take it easy at first!

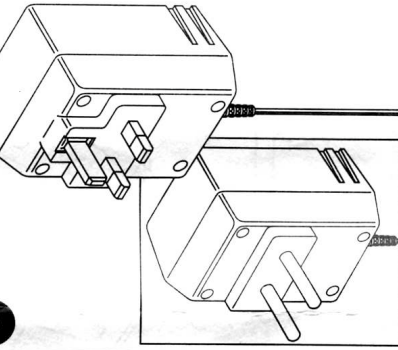

**6** When the race track is completely assembled, connect up the hand controllers and transformer to the power base track and plug the transformer into the wall socket. The red light on the power base will show that the power is "on".

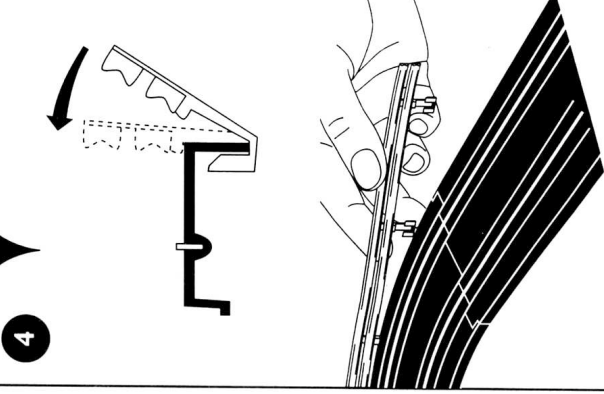

**7** Clip on the crash barriers by hooking the clips over the edge of the track and pulling them up straight.

## CAR MAINTENANCE

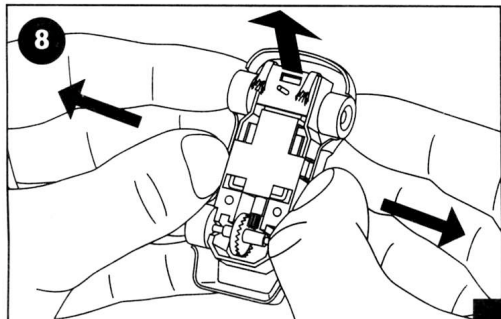

8 After a while, the pick-up braids underneath the cars may become worn out and need replacing. To do this, turn the car over and unclip the body from the chassis.

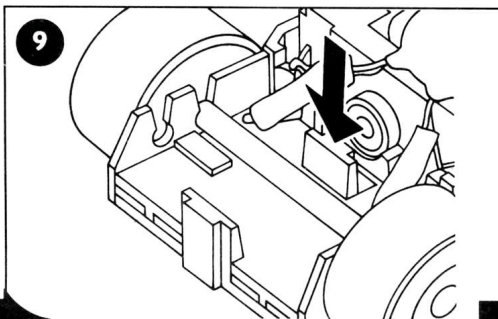

9 Unclip the rear of the braid plate by pressing down on the clip, from inside the car, as shown in the diagram. You may have to use a screwdriver to do this.

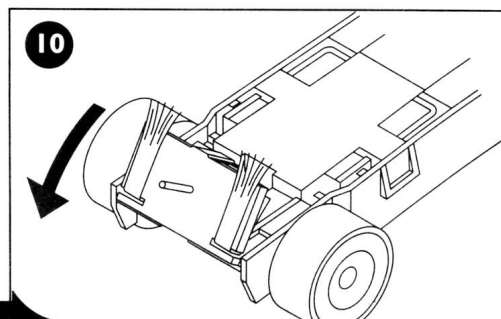

10 Turn the chassis over and remove the braid plate from its front clip.

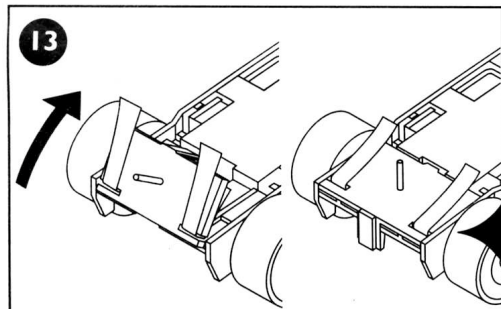

13 Fit the assembled guide plate assembly on to the chassis by engaging the front clip first and then the rear clip.

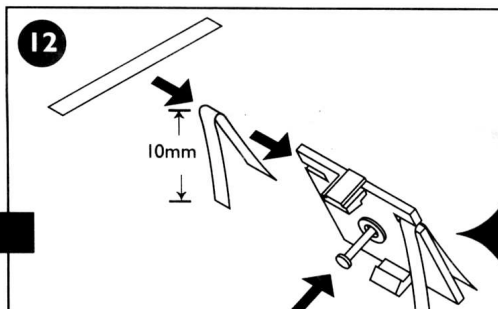

12 Fit new guide pin and braids to the braid plate. The braids should be folded so that the ends on top of the guide plate are 10mm long.

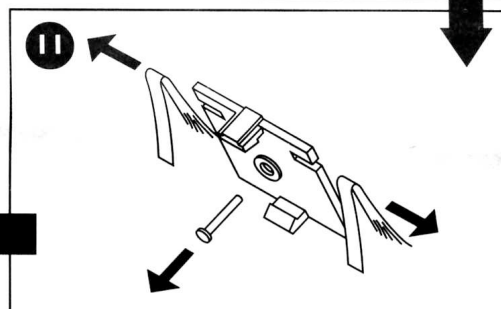

11 Remove the worn braids and guide pin from the braid plate.

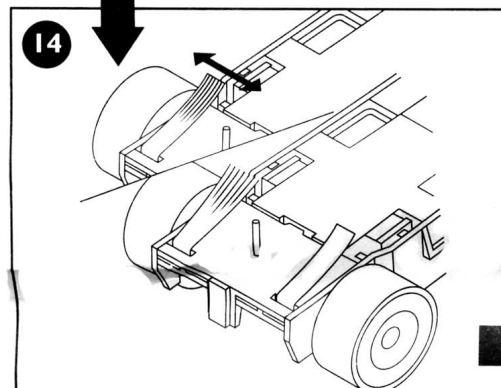

14 Refit the car body and tease out the ends of the braids so they make good contact with the pick-up rails in the track.

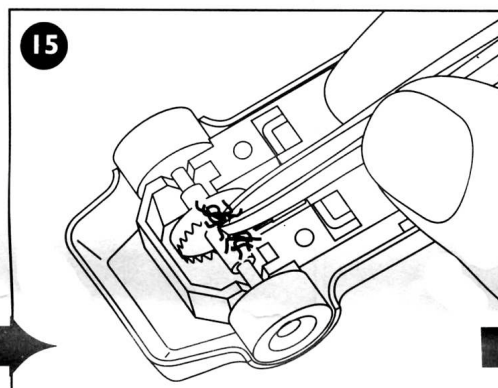

15 Remove any carpet fibres, pet hairs etc., from around the car's axles and gear wheel.

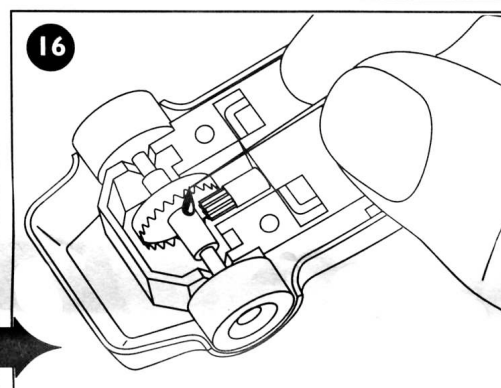

16 Periodically, oil the axle bearings and gear wheel with one drop of light machine oil.

## TRACK MAINTENANCE

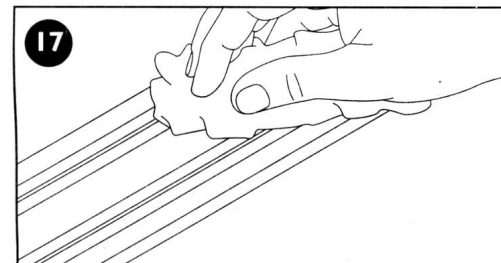

17 Always keep track clean by wiping over with a non-fluffy cloth, especially before putting the set away. Keep the pick-up rails shiny by rubbing carefully with a nylon "Scotch" washing-up pad or track cleaning rubber, reference R8087, obtainable from Hornby stockists.

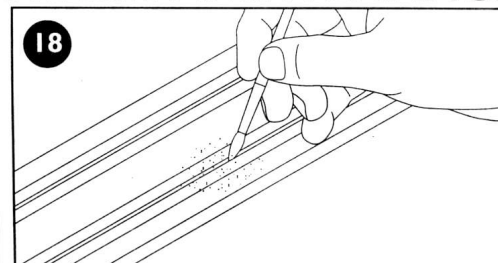

18 Keep the slot between the pick-up rails free from anything which would prevent the guide pin from travelling along it freely.

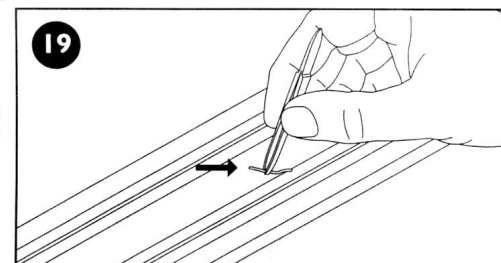

19 Make sure anything made of metal does not bridge the two pick-up rails which would cause a short-circuit.

20 If a short-circuit does occur, the automatic cut-out in the transformer will come into operation and shut off power to the track. In this case, unplug the transformer from the wall socket, eliminate the reason for the short-circuit and plug the transformer back in again. Note: The transformer must remain unplugged for at least 45 seconds to allow the cut-out to reset itself.